

PKS-PRO-E-50 - Servo System



FEATURES

- **Input Voltage Range of 170-253 VAC**
- **Rated Torque of 3,385 to 5,438 oz-in**
- **5.0 kWatt Power Rating**
- **No Load Speed of up to 2,000 RPM**
- **2,500 PPR Incremental Encoder**
- **Enclosed and Self-Cooled**
- **Oil Seal and Optional Brake**
- **MODBUS and CANopen Standard**
- **RS485 Interface**
- **Real Time Monitoring and Management**
- **Position, Speed, and Torque Control**
- **CE Certified**



DESCRIPTION

The PKS-PRO-E-50 servo system includes a 5.0 kWatt EMG or EML AC Servo Motor operated by the PRONET-E drive. These packages are ideal for quick and easy start-ups, convenience and performance! The servo motor included in this package provides torque from 3,385 to 5,438 oz-in. The PRONET-E drives offer current forward-feedback control, acceleration forward-feedback control, speed viewer, and inertia viewer; providing for improved response performance. These drives operate standard with MODBUS and CANopen protocol. Each system includes a 5M power cable, 5M encoder cable, and a 3M communication cable.

System Specs	Rated Speed (RPM)	Rated Torque (oz-in)	Rated Current (A rms)	Inertia (oz-in-sec ²)	Torque Constant KT (oz-in/A)	Resistance (ohms)	Inductance (mH)	Driver Digital Display	Brake (24VDC)	Motor Length (mm)	Shaft Diameter (mm)
PKS-PRO-E-50-A-GP22	2000	3385	28.0	0.9304	120.7	0.1	0.9	Yes	No	268	35
PKS-PRO-E-50-A-GP24	2000	3385	28.0	0.9757	120.7	0.1	0.9	Yes	Yes	339	35
PKS-PRO-E-50-A-LP22	1000	5438	24.0	1.4473	264.5	0.2	2.1	Yes	No	333	35
PKS-PRO-E-50-A-LP24	1000	5438	24.0	1.4926	264.5	0.2	2.1	Yes	Yes	399	35

ORDERING INFORMATION

PKS-PRO - E - 50 - A - G P 2 2

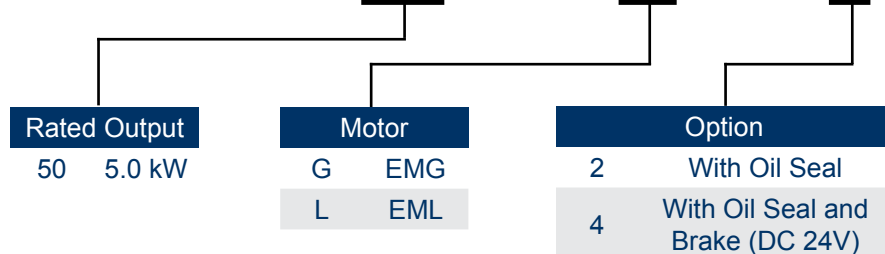

L010960

Servo Motor Specifications

FEATURES

- **Rated Torque of 3,385 to 5,438 oz-in**
- **3-Phase, 200VAC**
- **Rated Power up to 5.0 kWatts**
- **Peak Torque up to 300% of Rated Torque**
- **Peak Current up to 300% of Rated Current**
- **No Load Speed of up to 2,000 RPM**
- **2,500 PPR Incremental Encoder Attached**
- **Fully Enclosed and Self-Cooling**
- **Neodymium-Iron-Boron Magnets (NdFeB)**
- **Optional Brake Available**
- **CE Certified**



SPECS

Model #	Rated Torque (oz-in)	Rated Power (Watts)	Rated Speed (RPM)	Rated Current (A rms)	Brake (24VDC)	Inertia (oz-in-sec ²)	Electric Time Constant T _E (ms)	Back EMF Voltage K _E (V/krpm)	Torque Constant K _T (oz-in/A)	Resistance (ohms)	Weight (lbs)
EMG-50APA22	3385	5000	2000	28.0	No	0.9304	16.0	56.2	120.7	0.1	61.73
EMG-50APA24	3385	5000	2000	28.0	Yes	0.9757	16.0	56.2	120.7	0.1	61.73
EML-40APA22	5438	4000	1000	24.0	No	1.4473	20.2	118	264.5	0.2	103.62
EML-40APA24	5438	4000	1000	24.0	Yes	1.4926	20.2	118	264.5	0.2	103.62

DIMENSIONS

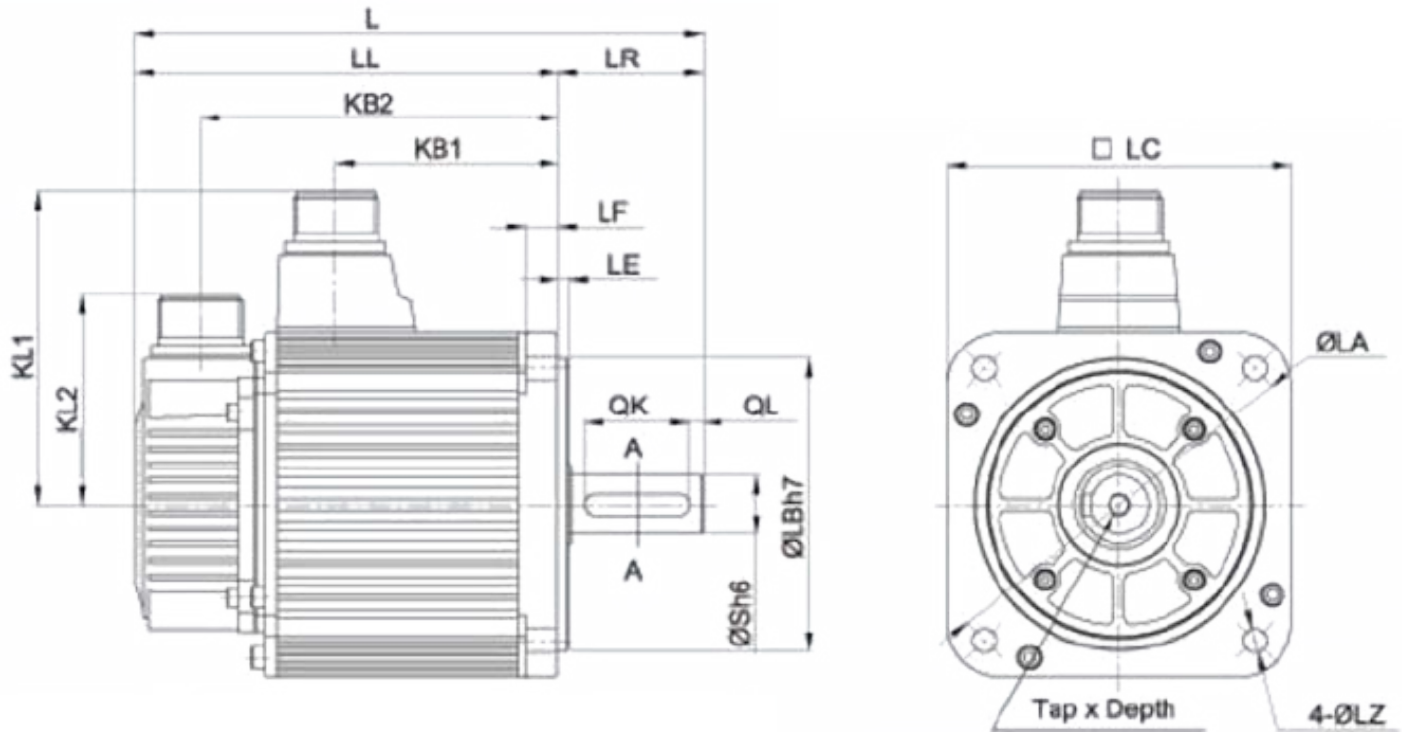

Note: All Dimensions in (mm)

MODEL #	L	LL	KB1	KB2	KL1	KL2	FLANGE SLIDE							S	TapxDepth	KEY				
							LR	LE	LF	LC	LA	LB	LZ			QK	QL	W	T	U
EMG-50APA22	347	268	183	243	140	79	79	3.2	18	180	200	114.3	13.5	35	M8x16L	55	6	10	8	5
EMG-50APA24	418	339	183	314	140	79	79	3.2	18	180	200	114.3	13.5	35	M8x16L	55	6	10	8	5
EML-40APA22	412	333	243	308	140	79	79	3.2	18	180	200	114.3	13.5	35	M8x16L	55	6	10	8	5
EML-40APA24	478	399	243	322	140	79	79	3.2	18	180	200	114.3	13.5	35	M8x16L	55	6	10	8	5

PRO-E-50 Driver Specifications

FEATURES

- Input Voltage Range of 170-253 VAC
- Rated Power up to 5.0 kWatts
- Improved Responsiveness Performance
- Enhanced Position Precision
- Low Speed Stability
- Enables Less Debugging
- MODBUS and CANopen Standard
- RS485 Interface
- Position, Speed, and Torque Control
- Homing Function



ProNet DIMENSIONS

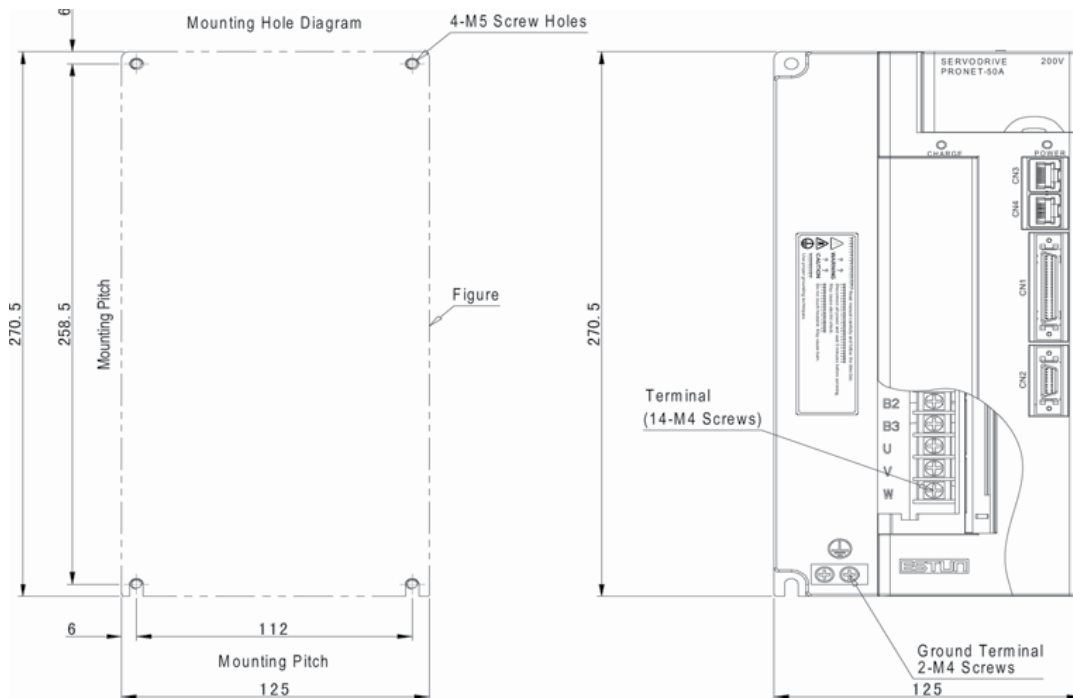

Dimensions are in millimeters (mm)

TORQUE CURVE

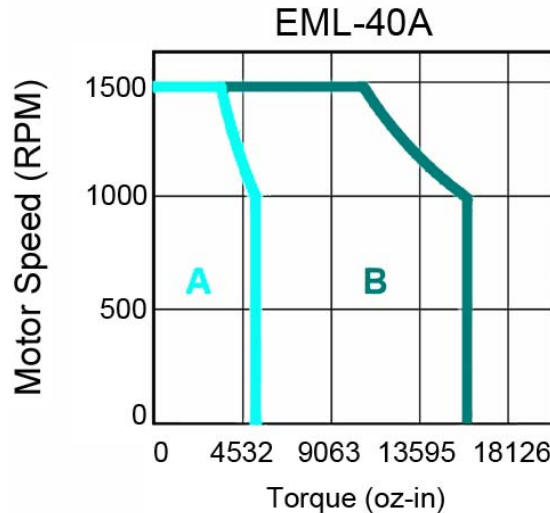
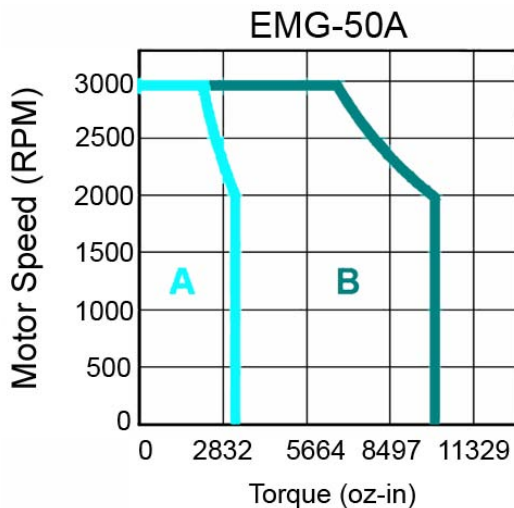

A - Continuous Working Area
B - Repeatedly Working Area

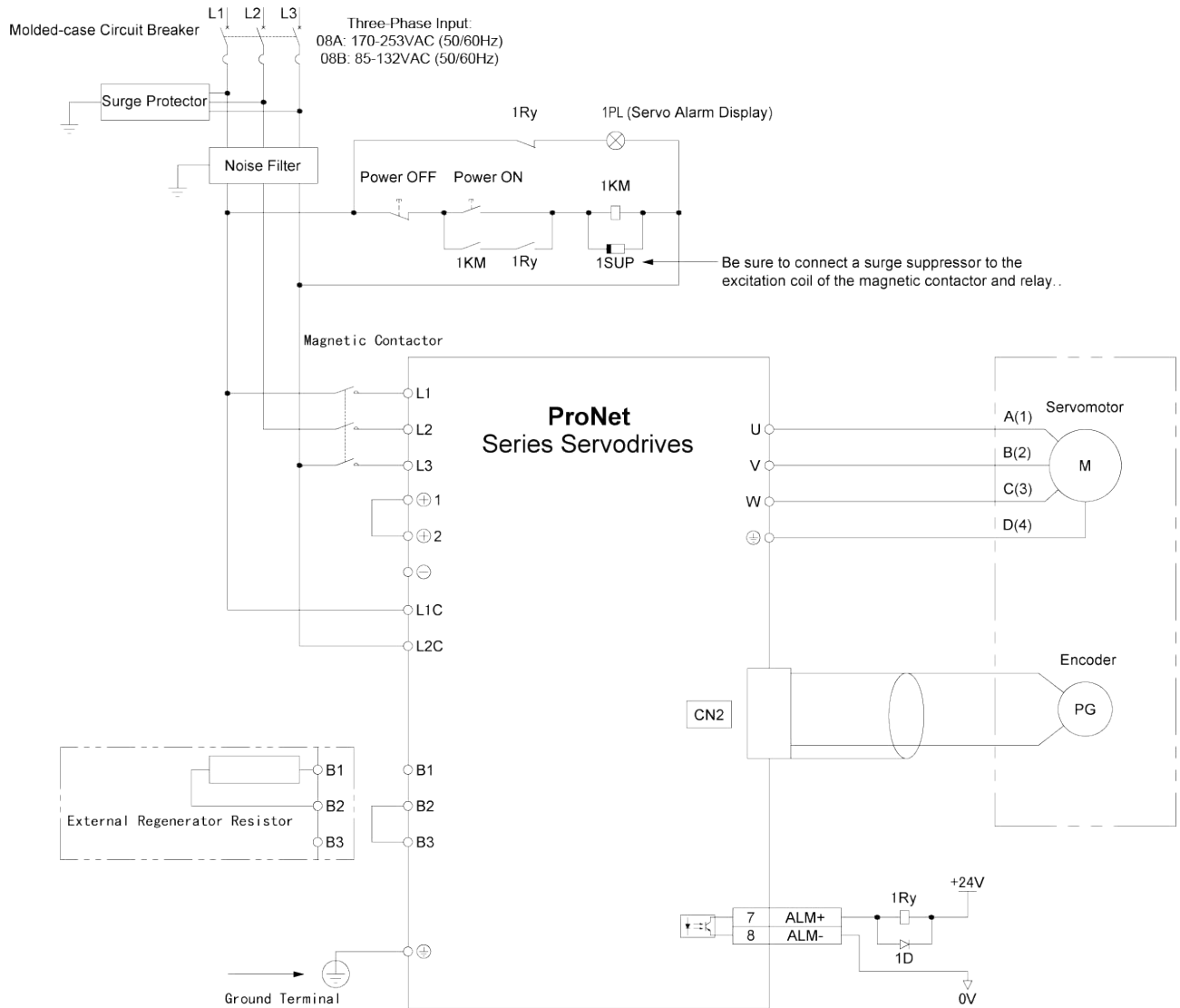

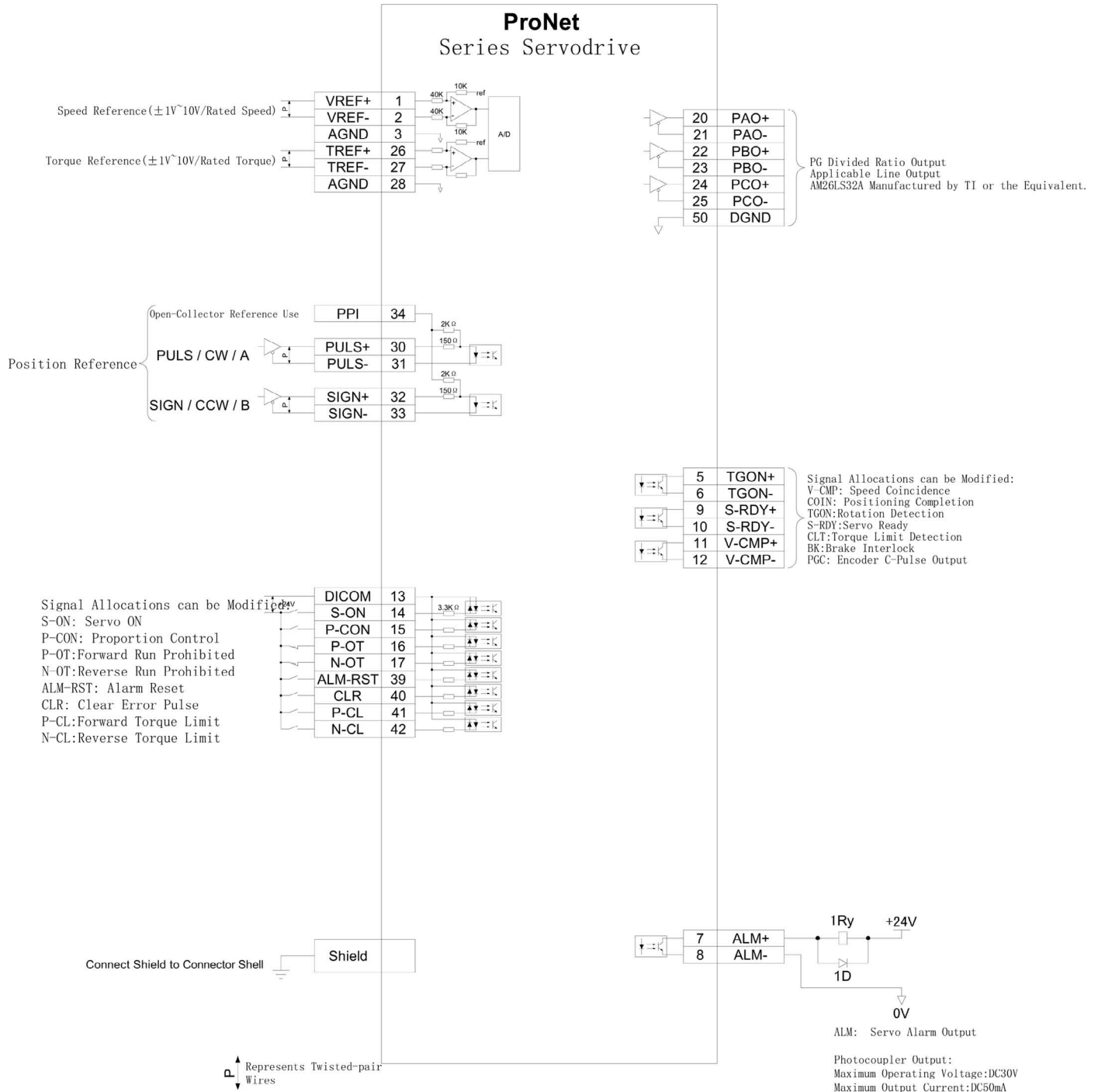

Compatible Drivers

Part Number	Description
PRONET-E-50A	Servo Driver



Compatible Motors

Part Number	Description
EMG-50APA22	Servo Motor
EMG-50APA24	Servo Motor
EML-50APA22	Servo Motor
EML-50APA24	Servo Motor



Compatible Cables

Part Number	Description
PDM-GD12-05	Power Cable
BMP-GA24-05	Encoder Cable
PRONET-PSC-CC24-02	Comm. Cable

